

FC2 Dual Grit

This drawing and the information contained herein is CONFIDENTIAL and PROPRIETARY to Friction Coating Corporation, is received in CONFIDENCE and shall not be used, copied, or disclosed to others without the written permission of Friction Coating Corporation. Doing so will result in legal action.

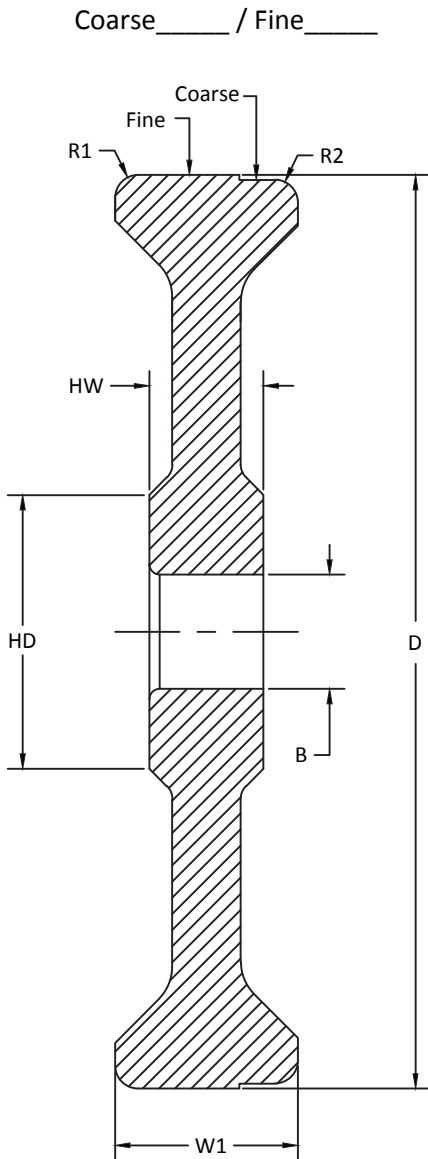

Coarse _____ / Fine _____

Grinding Wheel Information

D. Diameter: _____

W1. Width: _____

B. Bore (Finish grind size): _____

HW. Hub Width: _____

HD. Hub Dia. _____

Radius 1: _____ Radius 2: _____

Special Instructions: _____

Company: _____

Address: _____

City, State, Zip: _____

Country: _____

Contact: _____

Phone: _____

Fax: _____

E-mail: _____

Quantity: _____

P.O.#: _____



42770 Mound Road
Sterling Heights, MI 48314 • USA
P 586.731.0990 • F 586.731.0991

ORDER FORM

STANDARD TOLERANCES
UNLESS OTHERWISE NOTED:

0.0000 ±0.001
0.000 ±0.005
0.00 ±0.010

Dimensions are in inches

DATE

DRAWING NO.

REVISION

DRAWN BY

SHEET 1 of 1

* Grit selection: Use our "Grit Chart" located on the grinding wheel page.